

Hydraulic Valve Operating System For Two Wheeler

Lakshmeesha, M.S.

Abstract-Hydraulic Actuation Of Valve (HAV) is a mechanism to replace the mechanical actuation of valve in the 4 stroke IC engine presently in use. To overcome the disadvantages of the present system i.e. engine noise, oil leak at interfaces etc, hydraulic actuation mechanism is used, which eliminates some moving parts of 4 strokes engine like rocker arm, push rod tappet arrangement, cam chain, as well as some stationary parts like chain tensioner and, tension adjuster, thereby reducing the cost of production as well as weight of the engine and making the engine more compact. This mechanism has more advantages for two wheeler engine, especially for the engines having two spark plug for single cylinder as it reduces the engine weight. Due to less number of parts used. Heat transfer between the engine and atmosphere will be at a uniform rate at the cylinder block and cylinder head surface. Due to elimination of some moving parts of the engine, casting of cylinder head and cylinder block is easier.

Key Word: Hydraulic Actuation Of Valve (HAV), Internal combustion engine (IC),Single Over Head Cam Shaft (SOHC)

INTRODUCTION

Conventional 4 stroke IC engines completes 2 revolution for a single cycle and the air fuel mixture need to enter at the beginning of cycle by opening the inlet valve and closes at the 1st half rotation of crank shaft (i.e., at suction stroke). This suction stroke is followed by compression stroke and power stroke. At compression stroke air fuel mixture will be compressed to high pressure. At power stroke compressed charge will be ignited. Power stroke is followed by the exhaust stroke to remove the burnt gases from the combustion chamber. At exhaust stroke exhaust valve need to open at the end of 3rd half rotation and need to close at the end of 4th half rotation of crankshaft.

Opening and closing of valves is done by the cams. In modern IC engines inlet and exhaust valves are made to open and close by single shaft called camshaft. It has a series of cams along its length, each designed to open or close a valve during the appropriate part of an intake or exhaust stroke at appropriate timing.

Existing Mechanical valve actuation systems

As HAV gives best advantages for two wheeler. Earlier days 4 stroke engines are adopted with the pushrod mechanism to transfer the motion from the cams to valves, while camshaft is driven by the gear mechanism and located beside to the crankshaft. After the pushrod rocker will receives the motion. Then the other end of rocker arm transfers the motion to the valves to open the passage. It is same for the inlet and exhaust valves. In photograph red is the pushrod for exhaust valve and blue is for inlet valve and has housing on it.



Figure 1. Two wheeler engine with pushrod mechanism .

Author Details

- Lakshmeesha .M S ,DAE,B.E In Mechanical Engineering
South Western Railway, Mysuru Division, Mysuru,
Karnataka, India
PH-+919980090949.
E-mail: msslswr@gmail.com

To overcome these disadvantages today's engines are adopted with over head camshaft mechanism. In this camshaft is shifted to top of the engine i.e. to the cylinder head and it drive by the crankshaft by chain drive. In this pushrod is replaced by the cam chain. Some engines uses double overhead camshaft mechanism which has two separate camshafts for inlet and exhaust valves, single chain is used to drive both camshafts. In this rocker arm is not used.

Later to make the engine simpler and lighter single over head camshaft mechanism is used. In this single camshaft is mounted over the cylinder head and rocker arm is used to transmit the motion to the valves.

As chain is used there will be some disadvantages in chain drive i.e.

1. Running noise of the chain
2. Increase of chain slackness
3. Lubrication of chain and rocker arm etc.
4. Tappet noise.

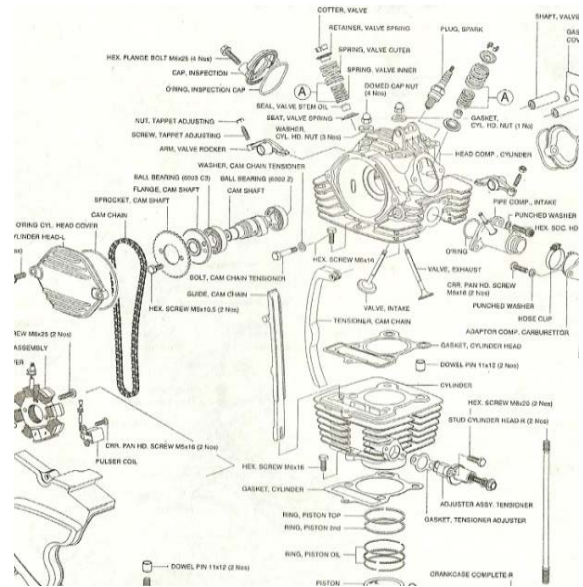

Figure 3. Exploded View of SOHC Engine

1. To reduce the running noise of chain drive guide cam chain is used.
2. To reduce the noise tensioner cam chain is used.
3. A tension adjuster is used to adjust the tension because excess tension also produces noise

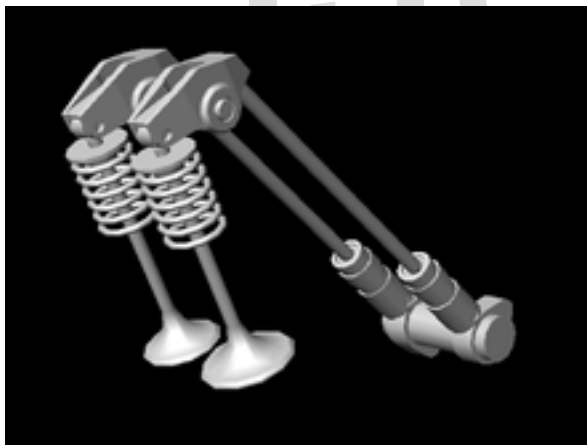

Figure 2. Pushrod mechanism.

Lubrication oil is pumped to the cylinder head to lubricate the over head parts like camshaft, camshaft bearing, rocker arm, rocker arm pin, etc.

Hydraulic Actuation Of Valve (HAV)

This design replaces the mechanical actuation of 4 stroke IC engine by hydraulic actuation system to overcome its disadvantages. Solid edge has been used to prepare its model. The main disadvantages of today's IC engines are.

5. It produce noise while running
6. It requires special care in design to prevent lubrication oil leakage.
7. Engine size increases due to valve operating mechanism in two wheeler.
8. Since rocker arm camshaft and chain drive operate at the cylinder head lubrication oil supply is there up to cylinder head.
9. Heat transfer is not uniform through the engine surface.

Hydraulic systems use an incompressible fluid, such as oil or water, to transmit forces from one location to another within the fluid. Most aircrafts use hydraulics in the braking systems and landing gear. Pneumatic systems use compressible fluid, such as air, in their operation. Some aircraft utilize pneumatic systems for their brakes, landing gear and movement of flaps.

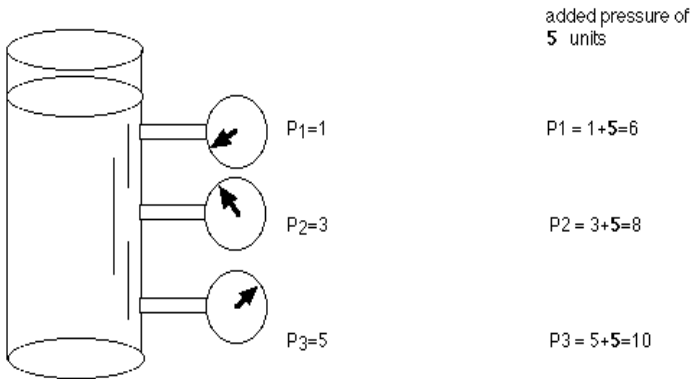

If the above container had an increase in overall pressure, that same added pressure would affect each of the gauges (and the liquid throughout) the same. For example P1, P2, P3 were originally 1, 3, 5 units of pressure, and 5 units of pressure were added to the system; the new readings would be 6, 8, and 10.

Applied to a more complex system below, such as a hydraulic car lift, Pascal's law allows forces to be multiplied. The cylinder on the left shows a cross-section area of 1 square inch, while the cylinder on the right shows a cross-section area of 10 square inches. The cylinder on the left has a weight (force) on 1 pound acting downward on the piston, which lowers the fluid 10 inches. As a result of this force, the piston on the right lifts a 10 pound weight a distance of 1 inch.

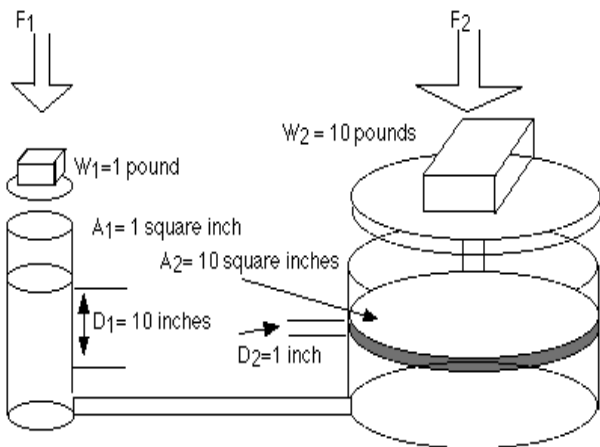

The 1 pound load on the 1 square inch area causes an increase in pressure on the fluid in the system. This pressure is distributed equally throughout and acts on every square inch of the 10 square inch area of the large piston. As a result, the larger piston lifts up a 10 pound weight. The larger the cross-section area of the second piston, the larger the mechanical advantage, and the more weight it lifts.

The formulas that relate to this are shown below:

$P_1 = P_2$ (since the pressures are equal throughout).
 Since pressure equals force per unit area, then it follows that

$$F_1/A_1 = F_2/A_2$$

It can be shown by substitution that the values shown above are correct,

$$1 \text{ pound} / 1 \text{ square inches} = 10 \text{ pounds} / 10 \text{ square inches}$$

Because the volume of fluid pushed down on the left side equals the volume of fluid that is lifted up on the right side, the following formula is also true.

$$V_1 = V_2$$

by substitution,

$$A_1 D_1 = A_2 D_2$$

A = cross sectional area

D = the distance moved

Or

$$A_1/A_2 = D_2/D_1$$

This system can be thought of as a simple machine (lever), since force is multiplied. The mechanical advantage can be found by rearranging terms in the above equation to Mechanical Advantage (IMA) = $D_1/D_2 = A_2/A_1$.

Hydraulic Actuation of Valve (HAV) Basic

HAV consists of two cam shaft cylinders, two valve cylinders and two oil lines from camshaft cylinders to valve cylinders. The design of the system is in such a way that it

doesn't need extra clamps or nuts to fit or hold the valve cylinders in its place. It's works on principle of Pascal's law In this mechanism no need of tappet gap since while thermal expansion takes place small volume of the oil flows back to reservoir and then flows back again towards the valve while the valve returns to its initial size. Reservoir provided with spring and piston to hold the oil up to the valve cylinder it opens a small hole exactly at the piston closes the hole as it moves up.

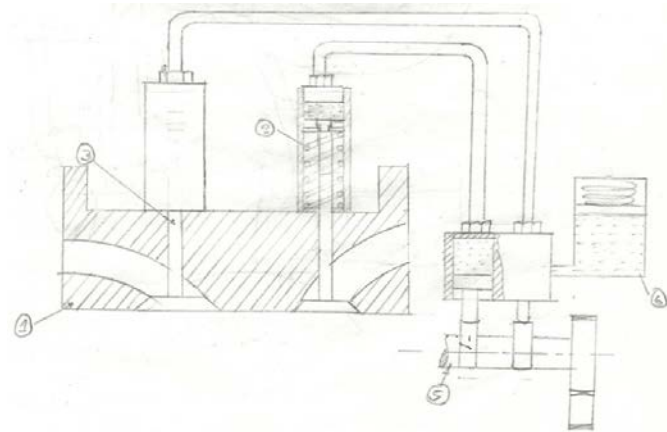

Figure 4. Schematic view of HAV
 The Following Components are.

1. Cylinder head
2. valve spring Valve
3. Camshaft cylinders
4. Camshaft
5. Reservoir
6. Valve cylinder

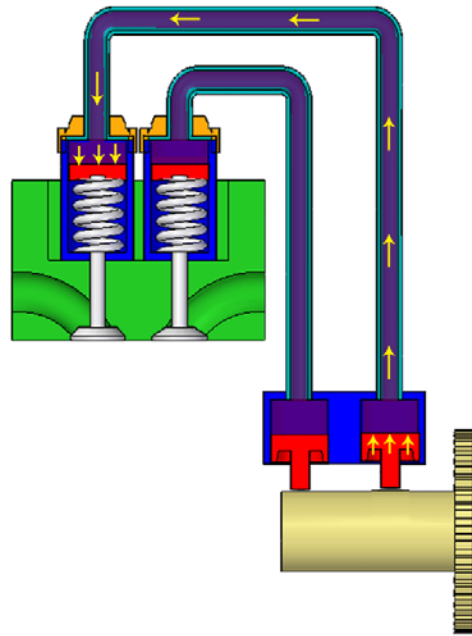

Figure 5.a. Opening Inlet Hydraulic actuation of valve .

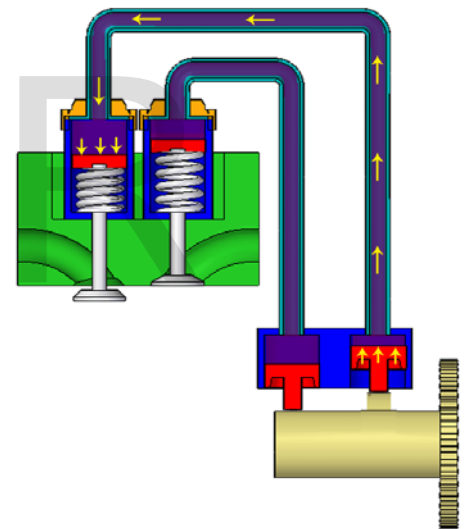

Figure 5.b. Complete Opening Inlet Hydraulic actuation of valve.

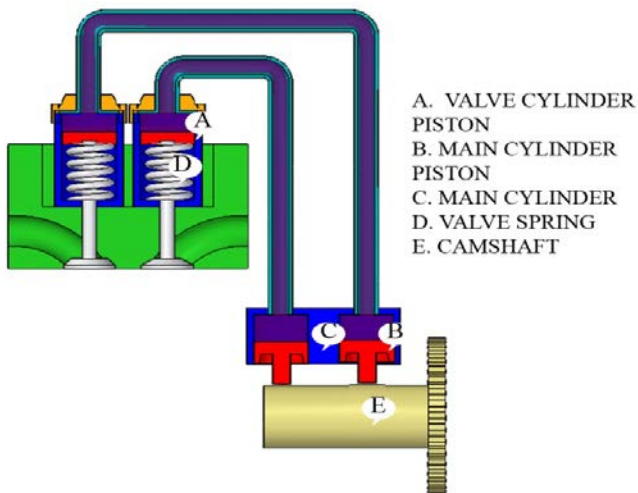

Figure 5. Hydraulic actuation of valve.
Below figures illustrates how the Hydraulic actuation of valve works.

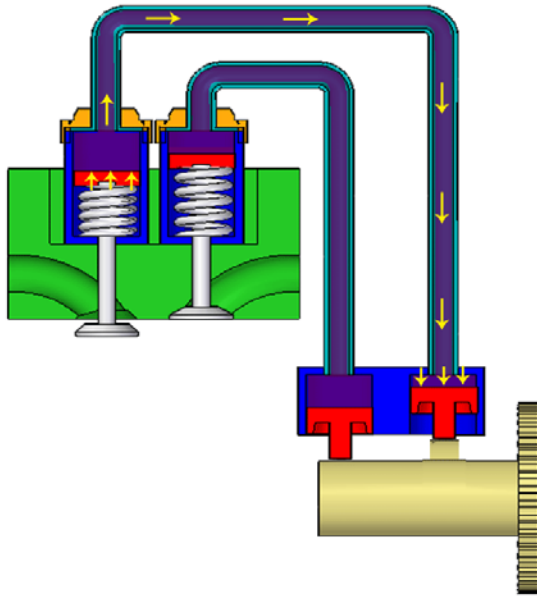

Figure 5.c. Hydraulic actuation of valve pressure decreasing.

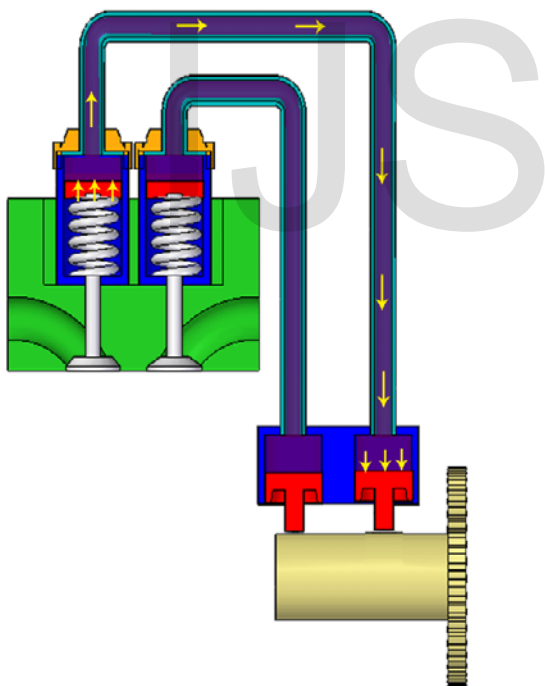

Figure 5.d. Inlet valve close and exhaust valve opening Hydraulic actuation of valve.

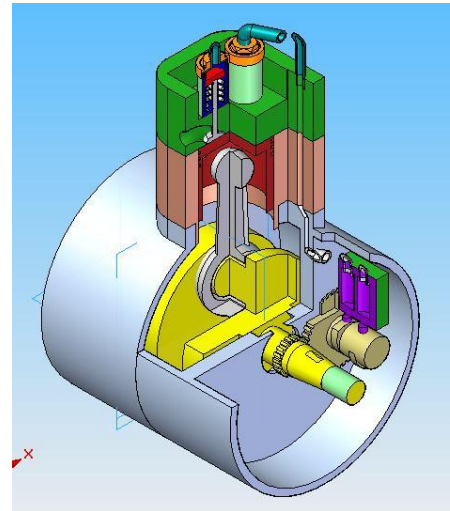

Figure 6 e. HAV final assemble,

This mechanism eliminates the chain drive and extra casting made for this so size of the engine is reduced by 10%. Machining cost required to mount the camshaft and rocker arm assembly at the top of the head is saved and it eliminates some mechanical parts so it reduces the cost.

Figure shows the comparison between the conventional engine and the HAV engine. Mechanical system has the chain drive from the crank shaft to camshaft and need housing, there is a passage for that to house the chain. And rocker arms are used to transfer the motion from the camshaft to the valves in mechanical system.

HAV is the modification of the pushrod mechanism where we can use hydraulic oil and replace the mechanical components related to valves.

1. In HAV system cam shaft can be place at any side of the crankshaft.
2. By the HAV system engine size can be reduced and small volume of the engine material is saved.
3. Some mechanical parts can be eliminated.
4. No need to carry the lubrication oil up to the cylinder head.
5. In HAV the oil path can be kept of any shape and size it is not restricted to any shape.

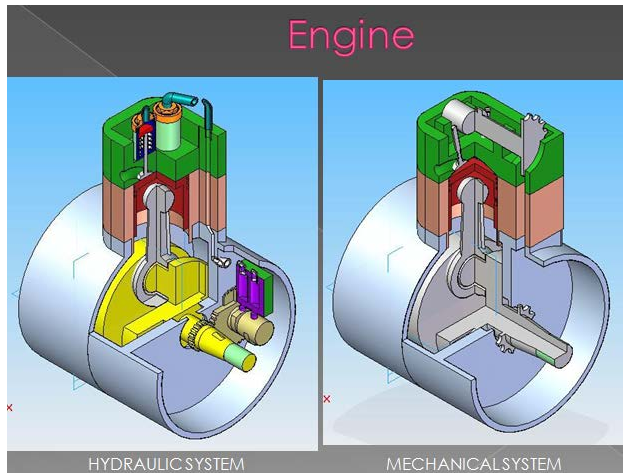

Figure 6. Comparison between Mechanical and Hydraulic system.

Fig 6, shows HAV basic mechanism and mechanical system. Head design of both HAV and SOHC. In HAV camshaft can be kept at any place but it need to rotate at half the speed of the crankshaft. Over the camshaft two main cylinders are mounted one for inlet valve and other for the out let valve. Two hydraulic lines carry the oil to the valve cylinders. This can be made in the cylinder block head and crankcase by drilling hole or forming the hole while casting. This oil enters the valve cylinders. The piston in the valve cylinder pushes the valve against the spring pressure and makes the passage to open. As cam approaches the descent profile pressure in the hydraulic line decreases and due to spring force piston pushes the oil back to the main cylinder. Same will be repeated for the exhaust valve, Shows in figure 5.

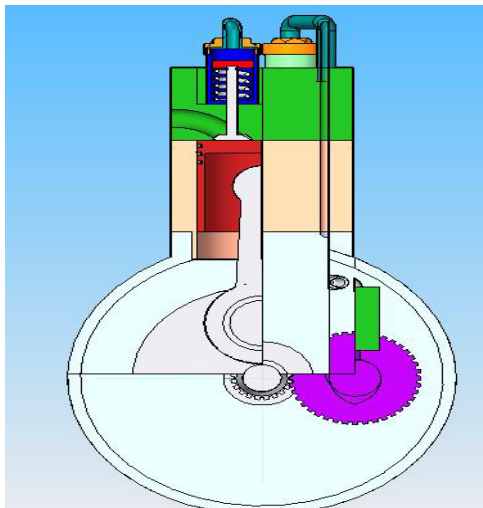

Figure 07. Hydraulic Actuation operating system

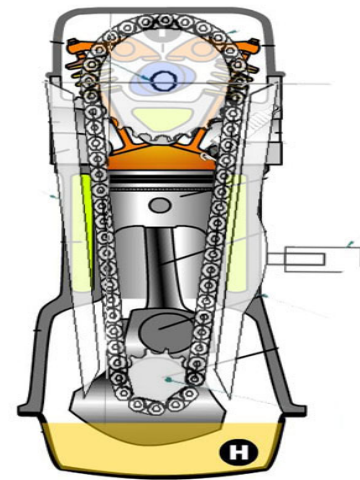

Figure 8. Existing Mechanical system.

Future Scope

And if this mechanism is used for 4 valve engine then both inlet valve can be operated by single profile. Only change to be made is the size of main cylinder has to be kept twice larger than the usual.

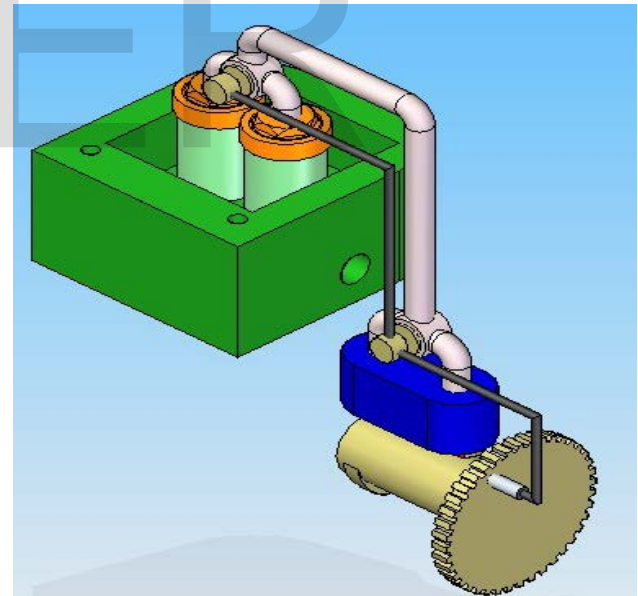

Figure 9. Future Scope of HAV system

Comparison between Cylinder Heads

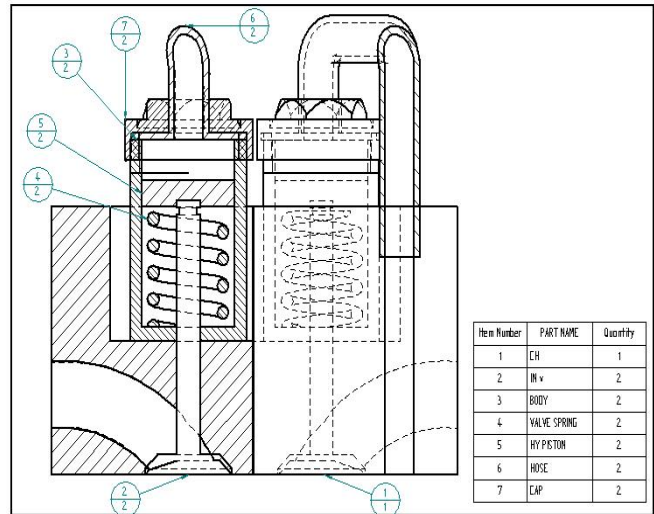
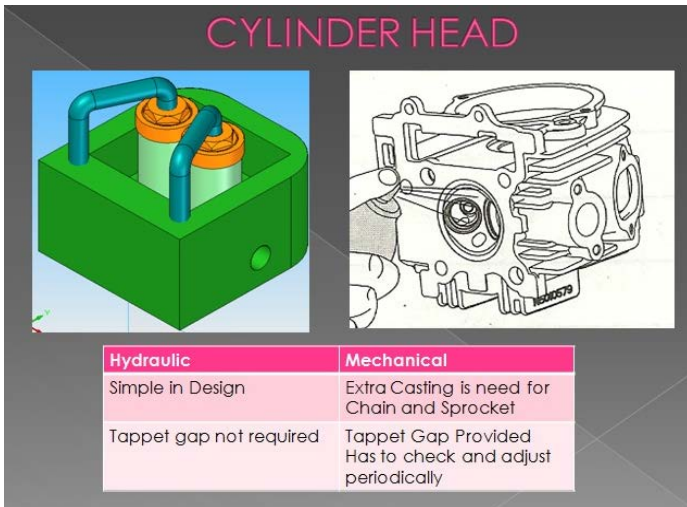

Figure 10. Cylinder Head Sectional View.

The above figure shows comparisons between existing mechanical cylinder head and hydraulic cylinder head moreover hydraulic system is more advantages compare to mechanical system. And less number of component, cylinder size is reduced.

Comparison with - Bajaj's DTS-I engine.

Comparison Between Cylinder Blocks

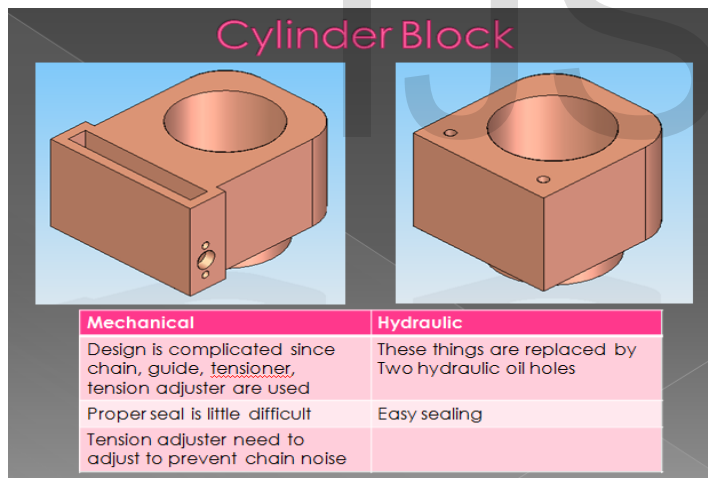

Figure 11. Bajaj's DTS-I engine

In this above comparison shows cylinder block between mechanical and hydraulic system, in mechanical system more components are available in cylinder block like chain guide for operating valve and tensioner, tension the adjuster are used. Proper seal is little difficult because of due to chain drive and tension adjuster need to adjust prevent chain noise so in hydraulic operating system these things are replaced and easy sealing.

This mechanism is very useful for the twin spark plug engine in twin spark plug single cylinder engine there is sealing problem for the one side sparkplug this can be seen in Bajaj's DTS-I engines.

Disadvantages

1. Two spark plug are at either side are at different angle because of chain system.

Cylinder Head Sectional View Of 2D-Drawing

2. Sealing is provided around spark plug.
3. Cooling is not effective at left side due to chain drive passage.

Advantages with HAV

1. Engine material can be saved.
2. Both spark plugs can kept at same angle in HVOS.
3. Extra sealing not needed.
4. Fins can also be provided at other end also

Conclusions.

1. In HAV system cam shaft can be place at any side of the crankshaft.
2. By the HAV system engine size can be reduced and small volume of the engine material is saved.
3. Some mechanical parts can be eliminated.
4. No need to carry the lubrication oil up to the cylinder head.
5. In HAV the oil path can be kept of any shape and size it is not restricted to any shape.

References

1. Automotive mechanics: Principles and Practices, Joseph Heitner, D Van Nostrand Company, Inc.
2. . Fundamentals of Automobile Engineering, K.K.Ramalingam, Scitech Publications (India) Pvt. Ltd.
3. Automobile Engineering, R. B. Gupta, Satya Prakashan, 4th edn.1984.
4. Automobile engineering, Kirpal Singh. Vol I and II 2002.
5. Oil Hydraulic Systems - Principles and Maintenance, S.R.Majumdar, Tata Mc Graw Hill publishing company Ltd.2011
6. Pneumatic Systems, S.R. Majumdar, Tata Mc Graw Hill publishingCo., 1995.
7. . Industrial Hydraulics, Pippenger, Hicks, McGraw Hill, New York.
8. . Fluid Power with applications, Anthony Esposito, Fifth edition pearson education, Inc. 2000.
9. Pneumatics and Hydraulics, Andrew Parr. Jaico Publishing Co.2000.
10. . www.highlights.com